

DOCUMENT RESUME

ED 249 442

CG 017 762

**AUTHOR** Zawadski, Rick T.; Gee, Stephen  
**TITLE** Computerized Information Management in Long-Term Care: A Case Study. Technical Report No. 303.  
**INSTITUTION** On Lok Senior Health Services, San Francisco, CA.  
**SPONS AGENCY** Administration on Aging (DHHS), Washington, D.C.  
**PUB DATE** Jul 82  
**GRANT** AoA-18-P-00156/9  
**NOTE** 29p.; Paper presented at the Annual Meeting of the Western Gerontological Society (30th, Anaheim, CA, March 17-21, 1984). Some figures are marginally legible due to small print.  
**AVAILABLE FROM** On Lok Senior Health Services, 1441 Powell Street, San Francisco, CA 94144 (\$2.50).  
**PUB TYPE** Reports - Descriptive (141) -- Speeches/Conference Papers (150)  
**EDRS PRICE** MF01/PC02 Plus Postage.  
**DESCRIPTORS** \*Case Reco ds; \*Community Health Services; \*Computer Oriented Programs; Computer Software; \*Information Systems; Money Management; Older Adults; Program Evaluation  
**IDENTIFIERS** California (San Francisco); \*Computer Managed Information; \*Long Term Care

**ABSTRACT**

This technical report describes the computerized information management system used at the Community Care Organization for Dependent Adults (CCODA) of the On Lok Senior Health Services in San Francisco's Chinatown (California). A background perspective on information systems in business, government, hospitals, and local community service agencies is given. The development of On Lok's information management system is described with emphasis on their specific needs and requirements. The hardware used in On Lok's system is described and diagrammed, including its central processing unit, printers, data storage, terminals, and remote capabilities. The firmware (i.e., operating system, programming languages, and word processing) is also described. The software, categorized by the fiscal management component, client management component, and the integrated database is described in detail. A discussion section focuses on the costs, benefits, utility, and cost effectiveness of computerization. Four recommendations to service providers considering computerization are listed. A summary of the On Lok system completes the document. (BL)

\*\*\*\*\*  
 \* Reproductions supplied by EDRS are the best that can be made \*  
 \* from the original document. \*  
 \*\*\*\*\*

ED249442

a community care organization for dependent adults

# computerized information management in long-term care: a case study



SENIOR HEALTH SERVICES  
BAHAY PAGASA  
CENTRO DI SALUTE PER GLI ANZIANI

安樂居

technical report

U.S. DEPARTMENT OF EDUCATION  
NATIONAL INSTITUTE OF EDUCATION  
EDUCATIONAL RESOURCES INFORMATION  
CENTER (ERIC)

X This document has been reproduced as  
received from the person or organization  
originating it.

Minor changes have been made to improve  
reproduction quality.

• If you know the person or organization that  
originated this document, please inform them of  
this service.

PERMISSION TO REPRODUCE THIS  
MATERIAL HAS BEEN GRANTED BY

*Richard J. Savada, Inc.*

TO THE EDUCATIONAL RESOURCES  
INFORMATION CENTER (ERIC)

CG 017762



## **what is on lok?**

Although On Lok means "happy, peaceful abode" in Chinese, On Lok Senior Health Services is much more. It is:

- a product of community concern for the frail older residents of the Chinatown-North Beach area in San Francisco;
- a freestanding, community-based model program which assists the elderly in helping themselves;
- a direct provider of all long-term care services from social support to hospitalization;
- a support system which, together with the family, helps the elderly remain in their own home, in their own community.

Since its inception in the early 1970's, On Lok's goal has been the same — to provide quality long-term care, i.e., care which is responsive to the total needs — medical, functional, social and environmental — of the disabled, dependent older adult. Support from the Administration on Aging (AoA), Housing and Urban Development (HUD), the National Institute for Handicapped Research (NIHR), the Health Care Financing Administration (HCFA) and private foundations and donations has enabled On Lok to respond to the multiple and interrelated needs of older people.

## **on lok's ccoda**

In 1979, On Lok established a Community Care Organization for Dependent Adults (CCODA) to provide all health and health-related services to those qualifying for long-term care. On Lok is studying whether an integrated, comprehensive health care system can provide a more cost-effective solution to the problem of long-term care.

On Lok represents the consolidated model of coordinated long-term care. Like other model projects, On Lok coordinates all long-term care services, but instead of referring to other providers, delivers those services directly. Through waivers, Medicare pays for all services provided. In contrast to projects focused upon the elderly "at risk," On Lok's CCODA serves only those who actually have been certified as eligible for institutional (skilled nursing or intermediate) care.

*continued on inside back cover..*

## **on lok senior health services**

**William L. Gee, DDS**  
President

**Marie-Louise Ansak, MSW**  
Executive Director

**Rich T. Zawadzki, Ph.D**  
Research Director

A TECHNICAL REPORT FROM ON LOK ...

**COMPUTERIZED INFORMATION MANAGEMENT  
IN LONG-TERM CARE:  
A CASE STUDY**

by:

**Rick T. Zawadski, Ph.D.  
Stephen Gee, B.S.**

This Technical Report describes the computerized information management system for On Lok's Community Care Organization for Dependent Adults (CCODA). It presents the background and rationale for the development of the information management system, describes the equipment, functions and role of the computer, appraises the system's benefits and costs, and makes recommendations for other human service programs.

On Lok's CCODA is supported by a grant from the Administration on Aging (#18-P-00156/9) and waivers granted by the Health Care Financing Administration under Section 222 of P.L. 92-603.

(Technical Report No. 303-July 1982)

CB 017762

©1982 by On Lok Senior Health Services  
All Rights Reserved

**COMPUTERIZED INFORMATION MANAGEMENT SYSTEM  
IN LONG-TERM CARE:  
A CASE STUDY<sup>1</sup>**

Despite the widespread recognition that we live in the age of computers, the use of the computer in long-term care settings remains underdeveloped, limited to traditional business functions such as payroll, external reporting, and word processing. While the computer does these things well, it can do much more to improve the quality and control the cost of long-term care.

This technical report focuses on the computer as a tool in meeting the broad information requirements of long-term health care programs--small as well as large, community-based as well as institutional. It provides a case study of the On Lok Information Management System (IMS), an information management system developed by an innovative community-based long-term care program using a microcomputer.

On Lok Senior Health Services is a non-profit, community-based service program which has been meeting the needs of the frail elderly in San Francisco's Chinatown-North Beach area since 1971. On Lok pioneered in the development of adult day health services, becoming the first state Medicaid demonstration site in 1974. In 1975, On Lok expanded its day center program into an outpatient continuum of multiple services. In 1978, On Lok was awarded a research and development grant to develop a complete long-term care system, a Community Care Organization for Dependent Adults (CCODA). Today, through the CCODA, On Lok provides all necessary health and health-related services--from translation to hospitalization--to clients who have been certified as eligible for institutional care.<sup>2</sup> To support that service program On Lok has developed a comprehensive and integrated fiscal and client information system. It has created and used a computer system to meet program, policy and research information needs.

To place On Lok's system in perspective, the "state of the art" with respect to information management is briefly reviewed, contrasting developments in business with those in health and human service programs. Then background information regarding the development of On Lok's system is presented, followed by a description of the system--its hardware, firmware, applications and software. Finally, the strengths and limitations of On Lok's approach are discussed and recommendations are offered.

## BACKGROUND

### Information Systems

In the business sector, sophisticated management has long appreciated the importance of information in decisionmaking. Management techniques, such as goal setting, Management-By-Objectives, and PERT, are predicated on the well-documented fact that knowledge of results affects performance. As

businesses became more complicated, jobs more specialized and organizations more complex, it became impractical without the aid of a computer to provide ready knowledge of results, i.e., feedback on performance. The development of the computer made it possible to put information to use in the business sector; the competitive advantages provided by information made the use of computers inevitable.

The first computers were mainframes, big, expensive and difficult to use. The advent of the microcomputer in the early '70's reduced the size and cost, and the development of conversational, user-friendly programs increased accessibility. As a result of these dramatic technological developments, the field has undergone a revolution. Software has become increasingly tailored to particular content areas, and computer literacy has spread among content experts. Now content experts--managers, accountants--work alongside and, in some cases, replace computer specialists and programmers in the development and design of systems. Computers have gone from centralized batch mode processing to decentralized interactive processing, and equipment is now in stores, small offices and homes.

How have computers affected the human service field? A mixed picture emerges. Major government programs, e.g., Social Security, Medicare, and many state Medicaid and Social Services programs, have long used big mainframe computers to manage central office procedures and billing. While these systems are useful--performing simple repetitive tasks in a fast, accurate and economical fashion--they are criticized because the information flow typically is "one-way;" office staff at the local level are given little feedback on what they do and how their performance compares with that of other similar units.

Hospitals have been more innovative in their use of computers. Borrowing from research laboratories, major university hospitals and now even local community hospitals have incorporated computers into patient care to aid in diagnosis and treatment, to monitor medical status, and to communicate information in an accurate and timely fashion. Computers have also played an expanding role in hospital management. Over the last decade, firms specializing in hospital management have applied sophisticated management theory and computerized information systems to improve efficiency and effectiveness. Some of the easily recognizable systems are MUMPS and COSTAR (Massachusetts General Hospital in Boston), HELP (Latter Day Saints Hospital at the University of Utah in Salt Lake City), PROMIS (at the University of Vermont), and MEDNET (by General Electric).

Barely touched by computers have been local community service providers. Of these, community-based long-term care health programs could especially benefit from computerized information management systems. Their efforts to coordinate numerous services, track clients' functional status over time, and meet the diverse accountability demands of multiple funding entities are hampered by the lack of information processing capability. In the past, these programs were considered too small to use sophisticated information systems advantageously; moreover, few professionals in human service programs have understood computer technology well enough to apply it. Thus, On Lok's experience has been unique and exceptional.

## The Development of On Lok's Information Management System

Like any other long-term health care program, On Lok Senior Health Services has a variety of information needs and accountability requirements. Its service staff needs to have scheduling information, to know the functional status of each client, and to determine the service needs of the client population. Administrative staff must monitor client census, service development, and program costs. Reimbursement agencies require an accounting of the program's census, of the services delivered, and of the costs of these services. Both internal and external evaluators need information regarding client characteristics, quality of care, services delivered, service costs, and client changes over time to measure the effectiveness of the project.

While the term, "Information Management System," may imply computerization to many people, the concept of the information system predates and is really independent of computers. All organizations deal with information, some more effectively than others. An information management system can be defined as the organization and integration of information into a system to meet organizational needs. An effective manual information system is the prerequisite to successful computerization.

Information has always played a critical role at On Lok, in part because of the fiscal and management concerns of the project's founders and in part because of the organization's expanding research and demonstration responsibilities. An efficient system was needed to collect client-specific data to meet internal service management needs as well as to gather fiscal and program data for reporting to On Lok's funding agencies.

On Lok's Information Management System (IMS) has been in development and use for over ten years. A manual information management system was first established to provide crucial program information, such as service, meal, assessment, and transportation schedules; attendance and insurance reports; name and address lists; service records; and cost and assessment data. Computerization allowed for faster, more accurate, more comprehensive, and more frequent production of that information.

When On Lok was awarded funds in 1978 to develop, operate and study its CCODA, it set as a top priority the development of an on-line computer system to automate and manage its information needs. Specifically, a system was needed to meet the following requirements:

- to record services to meet federal guidelines;
- to report cost, service and census data required by state and federal regulations;
- to access client biographical information--addresses, Social Security, Medicare and Medicaid numbers, demographics (including birthdates);
- to schedule services, transportation and meals;
- to monitor staff service activity;



- to follow client changes over time--individually and as a group--in terms of their functional and health characteristics;
- to track costs by individual, to link costs to service packages and to predict costs over time for particular client groups.

Since there was no system in the field which met these diverse yet important information needs, On Lok developed its own system designed for the community-based long-term care provider. This on-line, microcomputer-based system has now been operational for three years.

## SYSTEM DESCRIPTION

### The Hardware

The hardware used in On Lok's computer system is diagrammed in Figure 1. The term "hardware" refers to all the computer componentry, combining both digital and electro-mechanical devices. The dates in Figure 1 document the incremental expansion of On Lok's system.

The Central Processing Unit. At the center of the On Lok Information Management System is an Alpha-Micro Central Processing Unit (CPU), Model AM-100/T. All calculations and all data processing take place in the CPU, which has the capacity for multi-user multi-tasking. Using a version of the timesharing concept found on many larger computers, twelve different users can work separately, but simultaneously, on twelve different projects. The basic unit of computer memory is the byte. Currently On Lok has a total of 512 Kilobytes of Random Access Memory (512K of RAM) via 128 Kilobyte Random Access Memory boards. Traditionally, operators in much larger mainframe computer centers have operated with 64K of memory; each of On Lok's twelve users has in effect the same memory space available to them. For purposes of comparison, home computer users typically have 16K available, and can accommodate only one user.

Printers. The On Lok computer system uses three printers. One is a high speed dot matrix printer while two are slower, letter quality printers which use a variety of printwheels.

Data Storage. To store data and programs permanently, a 60 megabyte sealed Winchester disk drive and a Control Data Corporation 10 megabyte Hawk disk drive are used. Together these disk drives have a total storage capacity of 70,000,000 bytes (70 megabytes). This memory space is sufficient to store all active data and information files. For safety and security purposes, information from the disk drive is backed up regularly on magnetic tape and stored at a different location.

Terminals. Direct data entry and access is accomplished by seven Soroc 1Q (120 and 130 models) Cathode Ray Terminals, or CRTs, and five Televideo TVI-925 terminals, housed at all three of On Lok's day health centers as well as at the research department and the administrative offices. Each CRT has a keyboard almost identical to that of a typewriter and a keypad much like that of a 10-key adding machine.

**Figure 1**  
**THE ON LOK INFORMATION MANAGEMENT SYSTEM:**  
**HARDWARE DIAGRAM**

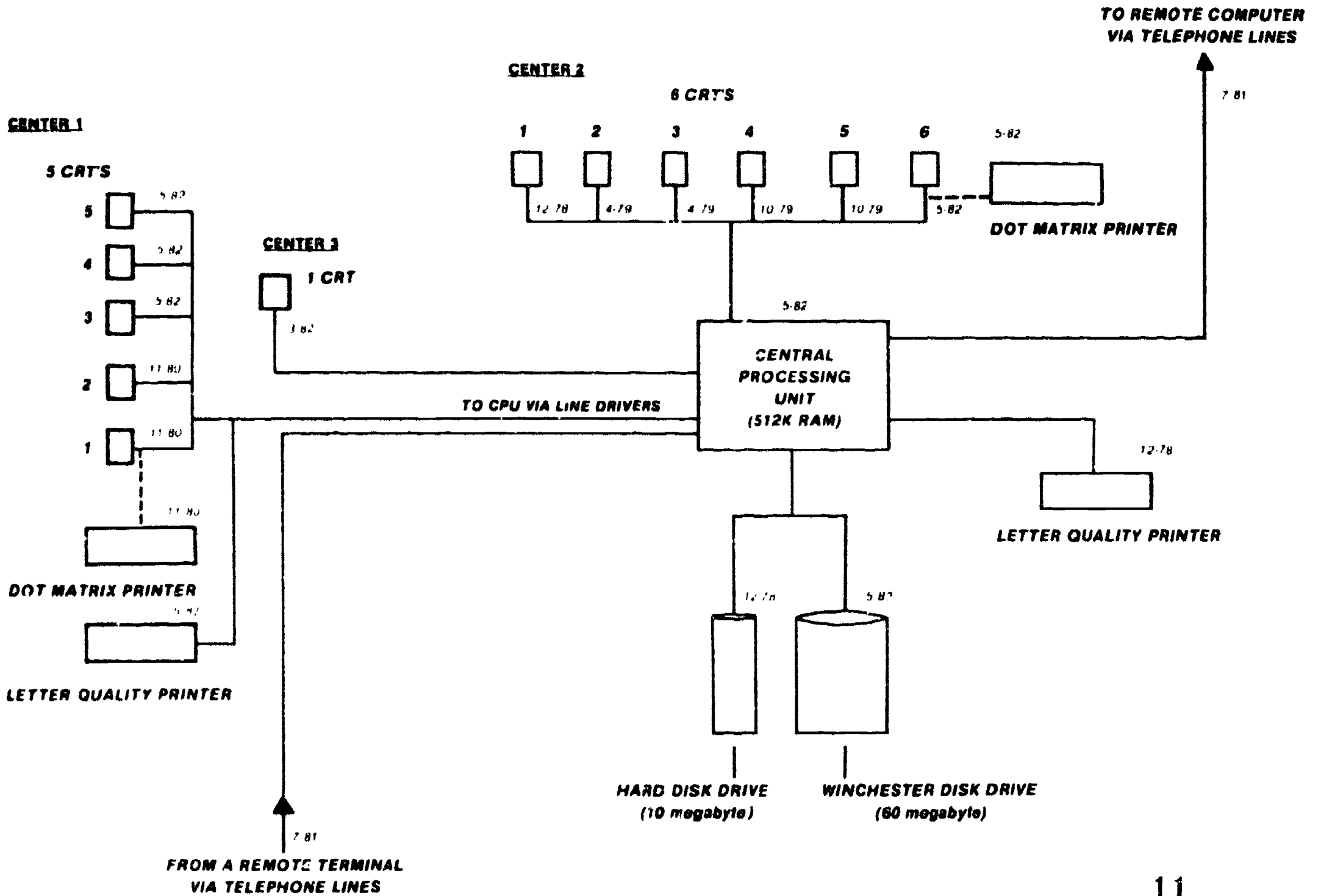

Remote Capability. On Lok's computer has remote access capability allowing anyone with a terminal, an interface modem and the proper password to dial into and use the computer through conventional phone lines. Some On Lok staff, in fact, have worked with the computer while at home.

Through the same type of telephone connection, On Lok's computer can be linked with any other computer having remote dial-in capability. On Lok has established communication links with the Atomic Energy Commission's Lawrence Berkeley Laboratory (LBL) in Berkeley, California, a CDC 7600 computer installation. Staff is able to edit data files, check job status, and run programs on the LBL computer from On Lok in San Francisco. This LBL link provides access to: 1) more sophisticated data analysis packages (e.g., SPSS, Biomed, Manova) required for some of On Lok's research; 2) an international data communication network (LBL is tied into other major university systems in this country and abroad); and 3) a wide variety of computer peripheral devices.

With remote capability, On Lok can electronically exchange data with other long-term care projects. In addition, it allows On Lok to share its system's extra capacity with other human service projects.

### The Firmware

"Firmware," a relatively new term to most computer users, is low-level software supplied by the manufacturer of the computer, in contrast to "applications software" which generally is written to meet the specific needs of the user. Firmware in On Lok's system includes its operating system, the computer languages used to program the computer, and word processing.

The Operating System. The operating system can best be thought of as a set of programmed instructions which manage the computer. The operating system programs allow the user to log in, log off, check who else is operating the computer, control passwords, determine what files are stored, and execute a variety of file commands: erase, copy, rename, type, and print.

The operating system employed at On Lok is the Alpha Micro Operating System version 4.6A, otherwise known as AMOS version 4.6A. Besides the functions mentioned above, AMOS 4.6A includes maintenance programs which protect the system against loss of data through disk or central processing unit errors.

Perhaps the most useful function of the operating system from a user's point of view is the password control function. The computer is divided into user accounts, each a private work area; if desired, several users can share the work space. To access an account, a password must be used. This password helps to protect against unauthorized use of a particular account. If a breach of security is suspected, the password can be changed without consulting the system operator.

The Programming Languages. On Lok has the facility to program in AMOS assembly language, AlphaLISP, AlphaBASIC, AlphaPASCAL, and Fortran 77. The AlphaBASIC programming language is the primary language used at On Lok, with a few statistical applications written in Fortran.

AlphaBASIC is simply a derivative of BASIC, the language now very popular with home and business computer programmers. AlphaBASIC has some unique and powerful data storage features which have allowed On Lok to keep the size of its data files to a minimum.

Word Processing. The word processing function eliminates the need for a separate, stand-alone word processor. Not only can documents be typed more quickly and accurately on the computer than on a conventional typewriter, but also anything entered into the computer can be stored and easily retrieved at a later date.

The word processing is facilitated by a very powerful text editor called AlphaVUE, commonly referred to as VUE, which allows the editing of any character on any page at any given time. Charts, tables and memos are easily created through VUE. VUE also is used to create all of On Lok's computer programs and can be used to edit operating systems and command files.

A text formatting program, called TXTFMT, helps to prepare VUE-created documents for presentation. TXTFMT sets margins, linesizes, and pagesizes; numbers or titles pages; makes indentations; creates chapter headings and numbers; and performs a host of other meticulous and tedious formatting chores.

### Software and Applications

On Lok's software system was developed to meet the special needs of the long-term care provider. An overview of the system is depicted in Figure 2. On Lok's software system can be divided into two distinct components: (1) Fiscal Management; and (2) Client Management. The Fiscal Management component performs all accounting functions, specifically accounts payable, payroll, general ledger, and fixed asset management, and provides fully integrated fiscal control. The Client Management component maintains basic information on all clients, i.e., participants in On Lok's long-term care service program, their characteristics, services received and health/functional status. An important design feature of On Lok's software system is the integrated data base, linking the Fiscal Management and Client Management components.

The Fiscal Management Component. The Fiscal Management component provides a comprehensive, integrated cash management system, bringing together personnel costs with other expenditures and enabling this information to be related to service data for effective fiscal control.

On Lok's computerized payroll system can distribute individual salaries to various funding sources through the general ledger. Hours worked are entered interactively into the computer. Computer records of each employee's deductions, exemptions and marital status are automatically recalled, and the payroll is calculated accordingly. Provisions are also available for special deductions such as tax-free retirement plans. Once the payroll checks have been generated, the checks are printed by the computer with the check stubs providing detailed employee information. Employee payroll records are stored in the computer, so any payroll information pertaining to any employee can be

**Figure 2**  
**THE ON LOK INFORMATION MANAGEMENT SYSTEM:**  
**MAJOR SOFTWARE COMPONENTS**

**Fiscal Management**

**Client Management**

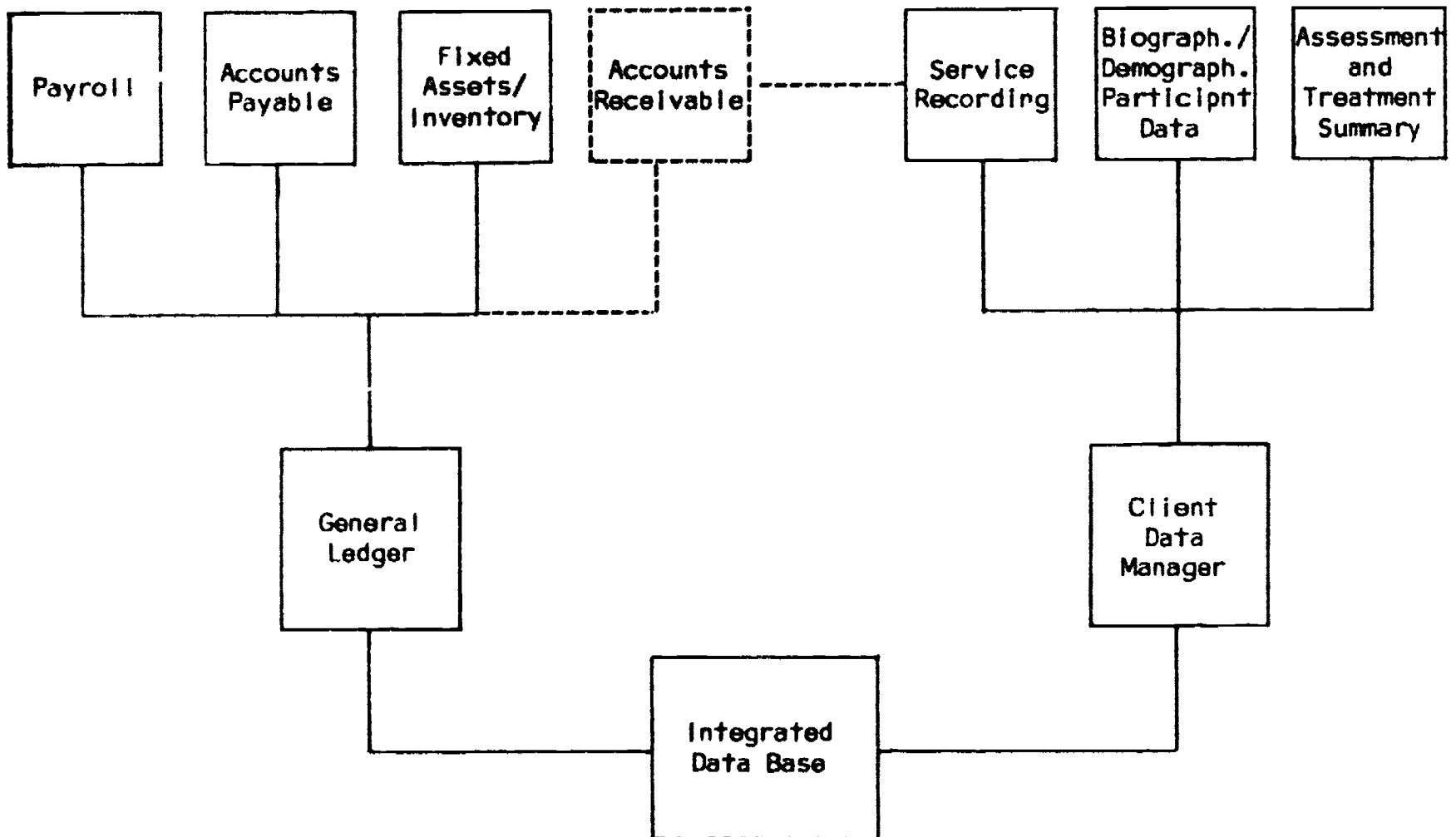

retrieved on demand by the proper personnel. All required tax reports (e.g., F941A and W2) are automatically computer generated. Together these features make the payroll system the core component of an employee record management subsystem.

The accounts payable system coordinates all expenditures outside of personnel costs. It maintains a chart of accounts for all expenditure categories, maintains complete vendor records, prints checks for all expenditures, maintains an ongoing record of accounts payable, tracks all expenditures by vendor, and produces regular reports on expenditures for a variety of fiscal periods.

The accounts receivable system, now being developed, will keep track of all amounts owed to On Lok for services it has rendered. It is being designed to prepare billing statements automatically, to monitor debts and to provide a comprehensive, current picture of all outstanding amounts. This system's development will be complete in early 1983 when On Lok institutes co-payment for some of its services. (Now all On Lok services are covered by Medicare under waivers, so separate billing is unnecessary.) The accounts receivable system will also be used to manage On Lok house's collection procedures (rent, deposits, etc.).

The fixed assets/depreciation system provides a complete inventory of all organizational assets above a predetermined value and calculates for a user-specified time period the depreciation accumulated by cost center. At the user's option, the depreciated values can be directly interfaced with general ledger. Inventory listings can be produced sorted by location, by cost center, by item identification number, or by cost.

Expenditures from accounts payable, payroll and depreciation are automatically interfaced through the general ledger system to provide a comprehensive perspective of program expenditures. The general ledger system provides flexible reporting by cost center, by funding source, by object code for any fiscal period (i.e., monthly, quarterly or annually). Budgeting capabilities allow On Lok to compare actual expenditures with budgeted values. Figure 3 shows some of the computer-generated reports related to the Fiscal Management component.

The Client Management Component. The Client Management component is designed to give administrative and service staff information pertaining to On Lok's client/participant population, such as demographic data, opening and closing dates, clients' income sources and amounts, and scheduling information. In addition, it is designed to meet all external reporting requirements and provide a data base for ongoing research.

At the heart of the Client Management component is the master participant system which contains identifying information on participants, enrollment-disenrollment data, scheduling information, biographical information, and demographics. This data set is used extensively in day-to-day operations, providing, on an ongoing basis, eligibility information for funding agencies, scheduling reports to program staff, and regular biographical summaries of the participant population.

**Figure 3  
FISCAL MANAGEMENT REPORTS**

RUN DATE: 3-DEC-81 ON LOK SENIOR HEALTH SERVICES PAGE 1  
 ACCOUNTS PAYABLE VOUCHER EDIT LIST

VOUCHER NO	VENDOR NAME	INVOICE NO	INVOICE DATE	AMOUNT	NON-DISC AMOUNT	DISC	DUE DATE	CHECK NO	DISTRIBUTION EXP-ACCT	AMOUNT
110001	01409 LIFE ASSURANCE		11/02/81	2,748.89	0.00	0.0%	11/02/81	1602	7204-301 7209-301 2030-700	2,400.12 24.40 324.37
110002	02513 PACIFIC BUSINESS CORP.		11/02/81	248.30	0.00	0.0%	11/02/81	1603	7710-301	248.30
110003	03301 ANCE CORPORATION		11/02/81	190.65	0.00	0.0%	11/02/81	1604	7630-301	190.65

RUN DATE: 8-DEC-81 ON LOK SENIOR HEALTH SERVICES  
 PAYROLL ATTENDANCE DISTRIBUTION REPORT  
 FOR THE PAY PERIOD ENDING 12/06/81 \* SALARIED EMPLOYEES' BASE PAY INCLUDED AS 40.00 REGULAR

DEPT NO	#-EMPS PAID	REGULAR MRS-PAID	OVERTIME MRS-PAID	VACATION MRS-PAID	HOLIDAY MRS-PAID	SICK-PAY MRS-PAID	SPC-RATE MRS-PAID	TOTAL MRS-PAID	MISC \$-PAID	#-MRS ADV-VAC	GROSS \$-PAID		
110006	01123 REC	11	14	840.00	0.00	16.00	24.00	72.00	0.00	952.00	40.95	0	5,904.55
110007	02108 A N								0.00	680.00	81.90	0	5,885.69
110008	01205 S.F.								0.00	756.50	4.33	0	4,661.80
									0.00	560.00	40.95	0	4,589.43
									0.00	80.00	0.00	0	2,040.00
									0.00	315.00	0.00	0	2,375.20
									0.00	298.00	0.00	0	1,971.85
									0.00	1,221.50	260.15	0	7,842.61

RUN DATE: 7-DEC-81 ON LOK SENIOR HEALTH SERVICES  
 PAYROLL ATTENDANCE EDIT LIST  
 FOR THE PAY PERIOD ENDING 12//81

NO	NAME	EMPLOYEE TYP	BASE PAY	HOURS				
				REG	OVRTIM	VAC	MOL	SICK
0001	DRIVER A	M	80.00	0.00	0.00	0.00	0.00	0.00
0002	THERAPIST B	M	64.00	0.00	0.00	8.00	8.00	0.00
0003	NURSE C	M	64.00	0.00	0.00	8.00	8.00	0.00
0005	DOCTOR J	M	72.00	0.00	0.00	8.00	0.00	0.00
0007	DIRECTOR K							
0008	NURSE L							
0009	SECRETARY							
0010	SOCIAL WORK ON LOK SENIOR HEALTH SERVICES							
0011	DOCTOR M							
0014	SUPERVISOR REPORT FOR P/E: 3 REGISTER							
0015	REC THERAP							
0018	HEALTH AIE							
0022	NURSE P							
0023	DOCTOR W							

RUN DATE: 4/9/82

G/L EXPENSE ACCOUNT LIST

ACCOUNT	CURRENT-MONTH	YEAR-TO-DATE	FIRST QTR.	SECOND QTR.	THIRD QTR.	FOURTH QTR.
1010100	498.48	518.48	0.00	60.00	458.48	0.00
1010800	67,483.00	120,977.46	0.00	53,494.46	67,483.00	0.00
1030500	0.00	3,445.00	2,790.00	370.00	285.00	0.00
1060100	0.00	13,628.25	13,628.25	0.00	0.00	0.00
1210110	0.00	4,907.44	4,216.25	691.19	0.00	0.00
1210130	0.00	2,119.35	0.00	0.00	2,119.35	0.00
1210150	626.07	5,917.71	1,310.67	3,980.97	626.07	0.00
1210300	0.00	4,902.07	1,712.39	3,189.68	0.00	0.00
1210400	0.00	3,900.00	0.00	3,900.00	0.00	0.00
2010100	0.00	5.00	0.00	5.00	0.00	0.00
2030100	30,227.46	184,158.52	65,914.39	51,753.12	66,491.01	0.00
2030200	2,359.74	26,788.79	9,171.48	9,793.29	7,824.02	0.00
2030300	15,609.26	91,940.61	30,499.45	26,603.70	34,837.46	0.00
2030400	1,157.70	7,394.45	2,766.63	2,278.08	2,349.74	0.00



A sample of a participant record listing from the master participant file is presented below in Figure 4.

**Figure 4  
SAMPLE PARTICIPANT RECORD LISTING**

1. Name	Duck, Daffy				
2. Adrs	20 Columbus Ave.	11. SW	58	20. Trans	51
3. Zip	94111	12. MD	20	21. Meals	120
4. Phone	421-7549	13. Mon	153	22. Evi Mo	61
5. OL #	0999	14. Tues	003	23. Status	756
6. SocSec	55566777	15. Wed	013	24. Center	1
7. Medicald	123456789019232	16. Thur	073	25. N-W	1
8. Medicare	NONE	17. Fri	083	26. S-E	4
9. CareCov	AB	18. Sat	011	27. CtrMeals	3
10. Medi-Cal	1	19. Sun	051	28. Other	0

The master participant system is dynamic; information is updated as changes occur. The system is divided into two data sets, one for presently active clients and one for closed cases. Using the data base described above, many different reports can be generated including:

1. Name and address list
2. Seven-day scheduling for day health center attendance
3. Transportation scheduling
4. Meals scheduling
5. Intake and assessment evaluation dates
6. Insurance/Medicare coverage reports
7. Participant birthday list
8. Participant weekly status report
9. Biographical summary report

Figure 5 displays some of these reports.

The service data file of the Client Management component contains all service utilization data. These data summarize the number of service users, the total number of service units used, and the number of units per user, and present this information for level of care, user payment source, and service setting. Service staff record each day of service delivered in over fifty



## Figure 5 CLIENT MANAGEMENT: MASTER PARTICIPANT REPORTS

IN-LIAISON HEALTH SERVICES PAGE: 1 JUNE 4, 1981

10 Names in Combined Address List  
Distributed to CENTER SUPERVISORS

Name	OLE	Address	Phone	SS NO	WTR	STAT	D.O.B.
DUCK, DORRY	00001	20 COLUMBUS AV.	421-1660	90 20	1	990	12/29/08
FOODOR, ANNETTE	01204	29 000/107E PASADENA	670-7001	7 27	1	990	05/11/18
HESS, ROBERTA	00700	3 EASTWIND VILLAGE RD	6000	4 23	1	781	02/28/19
HESTER, RILEY	00004	1 SHILOH WAY	123-4555	09 30	2	420	12/10/70
LAY, SUSAN	01111	2 SOUTHERN BELL RD.	612-7600	49 09	1	910	02/18/14
LINCOLN, ANN	00007	34 LINCOLN AVE.	790-2770	90 20	2	790	10/08/20
MONROE, MONTE	00001	278 POND ST.	405-7777	4 04	1	490	01/08/08
ROBERTSON, DORIS	00004	71 FLAGERS AVE.	620-5100	00 10	2	900	12/24/08
				02 00	1	990	12/21/08
				99 01	1	910	02/18/10

IN-LIAISON HEALTH SERVICES PAGE: 1 6/2/82 REPORT.DAT

PARTICIPANT WEEKLY STATUS REPORT

274 ACTIVE PARTICIPANTS      2 NON-ACTIVE PARTICIPANTS

MEDICARE CAL 129    47.08 \$  
 MEDICARE ONLY 121    44.18 \$  
 MEDICAL ONLY 10    4.29 \$  
 NONE 18    9.11 \$

NO. OF CARE TOTALS      PLACEMENTS TOTALS

02 HOME	03 Unemployed
04 HOME	04 Home w/other
05 Home with	100 Home Alone
06 Boarding	41 OL -Private Hosp
07 Day Care	17 OL -Private Hosp
28 CC	0 Board & Care
8 HOME	0 In-Patient - Care
0 Skilled	12 Skilled Nursing
2 Inpatient	1 Home Care
0 Other	0 Home Care

276 Total Participants      276 Total Active

DAILY SCHEDULED ATTENDANCE TOTALS

Day	Monday	Tuesday	Wednesday	Thursday	Friday	Saturday	Sunday
PROG. CT	68	68	67	66	67	62	64
REGISTRATION	90	90	91	91	91	100	00
WORK ST	62	61	64	58	60	70	00

IN-LIAISON HEALTH SERVICES PAGE: 1 JUNE 4, 1981

Master Participant Scheduling List  
Distributed to CENTER SUPERVISORS

NAME	OLE	SS NO	REAL	TRN	ED	Mon	Tue	Wed	Thu	Fri	Sat	Sun
DUCK, DORRY	1	90 20	120	91	01	01	01	01	01	01	01	01
FOODOR, ANNETTE	1204	7 27	130	01	01	01	01	01	01	01	01	01
HESTER, RILEY	4	09 30	170	01	01	01	01	01	01	01	01	01
LAY, SUSAN	1111	49 09	100	01	01	01	01	01	01	01	01	01

PARTICIPANT DESCRIPTION  
Effective through December 1981

PERSONAL CHARACTERISTICS

AGE (N = 264)	SEX (N = 264)	MARITAL STATUS (N = 264)	NUMBER OF CHILDREN (N = 274)
14 - 20 16	Male 105	Single 129	None 149
21 - 30 12	Female 48	Married 29	One 18
31 - 40 58		Divorced 6	Two 16
41 - 50 41		Widowed 48	Three 12
51 - 60 8		Separated 5	Four or more 21

ETHNIC CHARACTERISTICS

ETHNICITY (N = 260)	PRIMARY LANGUAGE (N = 260)	ENGLISH FLUENCY (N = 273)
Chinese 79	Chinese 148	None 149
Caucasian 11	English 16	Little 27
Hispanic 4	Tagalog 4	Fair 15
Other Asian 1	Spanish 4	Fluent 20
Other 1	Other 1	
Other Asian 1	Other 0	

USUAL LIVING SITUATION (N = 273)

Situation	Count
Alone	10
With Spouse Only	10
With Other Relatives (w/ or w/o Spouse)	10
With Room Mate(s)	0
In Supervised Housing	0
In a Board and Care Facility	0
In a Skilled Nursing Facility	0
Other	0

IN-LIAISON HEALTH SERVICES PAGE: 1 MULTIPLE DATES DATA

PARTICIPANT RESPONSE INFORMATION  
IN RELATED TO AREA

NAME	OLE	SS NO	Med Care	COV	OPEN DTE
DUCK, DORRY	00001	12547670	12549704	A	6/4/82
FOODOR, ANNETTE	01204	22150499	22150490	AB	10/22/81
HESTER, RILEY	00700	40122900	40122900	AB	4/1/82
HESS, ROBERTA	01541	12229400	12229400	AB	5/31/82

IN-LIAISON HEALTH SERVICES PAGE: 1 6/2/82 REPORT.DAT

PARTICIPANT DESCRIPTION STATUS REPORT

New Participants

OLE	NAME	STATUS	ADDRESS & PHONE	EFFECTIVE D
00001	DUCK, DORRY	1	20 COLUMBUS AV. 421-1660	01/21/82

Help-Placed Participants

OLE	NAME	STATUS	LOCATION	EFFECTIVE D
00001	DUCK, DORRY	1	20 COLUMBUS AV.	01/21/82

Skilled Nursing Home

OLE	NAME	STATUS	LOCATION	EFFECTIVE D
01204	FOODOR, ANNETTE	1	29 000/107E PASADENA 670-7001	05/21/80
00700	HESTER, RILEY	1	1 SHILOH WAY 123-4555	12/10/70
01111	LAY, SUSAN	1	2 SOUTHERN BELL RD. 612-7600	02/18/14

Supervised Housing

OLE	NAME	STATUS	REASON FOR SUPERVISION	EFFECTIVE D
01111	LAY, SUSAN	1	011 - 1316 - Phone	05/20/82
00007	LINCOLN, ANN	1	042 - 1078 - Phone	10/08/20
00004	HESTER, RILEY	1	041 - 1078 - Telephone	12/24/80

Resp To Unit

OLE	NAME	STATUS	DATE
00001	DUCK, DORRY	1	App 1/10/82
01111	LAY, SUSAN	1	App 6/2/82

Inactive Participants

OLE	NAME	STATUS	LOCATION	EFFECTIVE D
00001	DUCK, DORRY	1	20 COLUMBUS AV.	05/20/82
00004	HESTER, RILEY	1	1 SHILOH WAY	12/10/70

FINANCIAL CHARACTERISTICS

TOTAL MONTHLY INCOME (N = 267)	SOURCE OF INCOME (N = 267)	RESIDUAL ELIGIBILITY (N = 260)
\$1 - \$100 75	SSA 70	Medicaid Only 18
\$101 - \$200 14	SSI 10	Medicare Only 48
\$201 - \$300 14	Pension 14	Medicaid/Medicare 44
\$301 - \$400 01	Unemployment 2	None 6
\$401 - \$500 0	Family Support 0	
\$501+ 0	Other 0	
Mean = \$429.00	None or more sources 14	

\*B) Differences from NONE due to rounding error



service areas from transportation to counseling to hospitalization. These data, supplemented by data for specialty services derived from medical billing, are summarized monthly and computerized. Monthly service data are summarized quarterly and annually, and those summaries have become a regular part of On Lok's quarterly progress reports. (Samples of these summaries are presented in Figure 6.) Service data can be evaluated to identify service patterns among participants and used in regression analyses as predictors of functional change. In 1983, service data will be used to generate co-payment billings.

The assessment data file includes information on each client's health status (medical/diagnostic condition and functional impairment levels) and physical environment, as assessed by individual members of the On Lok multidisciplinary team. These multidimensional data are intended to describe individual clients as well as the target population and to enable the measurement of change in individuals and the population. Some examples of assessment variables are:

1. Case number
2. Admission date
3. Variables for level of care (9)
4. Level of impairment of basic skills (9)
5. Assistive devices used (11)
6. Level of impairment of psychosocial functions (14)
7. Requirements of living variables (10)
8. Treatment/service plan variables (46)
9. Medical summary variables (53)
10. Nursing and daily living variables (21)
11. Variables referring to living quarters (15)

Ongoing information on client functional status is available through the computer. (See Figure 6 for samples of reports.) Some factor analyses of the functional assessment data set and some initial analyses of change over relatively short one-year periods have been completed. In addition, these data are being used to assess changes over a longer period of time and, in conjunction with service and demographic data, being used to study predictors of change.

Integrated Data Base. The real advantage of a single, coordinated information management system is the ease of integrating discrete components into a common data base. The computer system developed at On Lok, for example, has been designed to integrate cost information with service information. Such a data structure allows maximum flexibility in aggregating costs along different dimensions to provide information on the service program and on the individual's service package. Cost per service unit is reported on a regular basis and has been used in conjunction with client identifiable expenditures and individual client service records to produce a cost per client per month variable. (An example of unit cost reporting is included in Figure 6.) In turn, that variable is used as a criteria measure to examine cost distributions among clients with different degrees of impairment, change in costs over time, and predictors of cost.

**Figure 6**  
**CLIENT MANAGEMENT:**  
**SERVICE, ASSESSMENT AND INTEGRATED REPORTS**

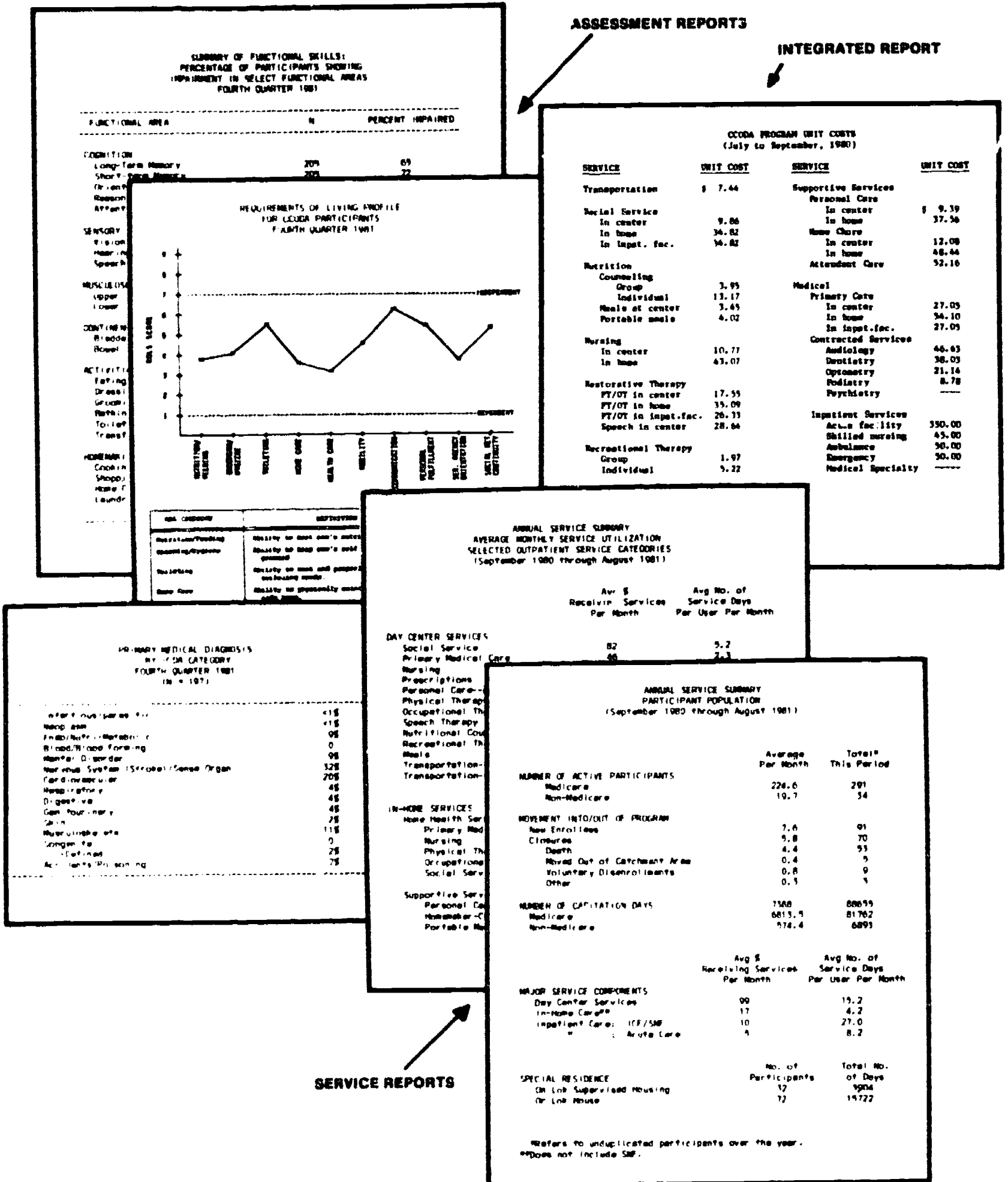

## DISCUSSION

Is computerization cost-beneficial, cost-effective today? What are the costs and benefits of the On Lok system? Would such a system work elsewhere? Based upon the On Lok experience, what recommendations could be made to other human service organizations considering computerization?

This discussion section addresses some of these frequently asked questions.

### Computerization--Is It Worth It?

Today On Lok continues to refine its computerized information system--improving efficiency of present systems, adding new subsystems and routines, and exploring new roles for computerization in human service settings. With all major elements of On Lok's computerized information system now fully operational, some of the costs and benefits of developing and operating such a system can be assessed.

Costs. Many small to medium human service providers find computerization to be desirable, readily acknowledging its benefits but not giving such systems serious consideration because costs presumably are prohibitive. Providers recount others' "horror stories" of spending large sums of money for incomprehensible equipment designed and operated by people with whom they could not communicate and, not surprisingly, resulting in limited, if any, benefits. Fortunately, recent technological developments make possible a very different scenario.

A full assessment of cost must consider not only the financial costs for equipment and application systems, but also other organizational costs of making the transition to such a system.

1. Financial Costs. In 1978, for about \$19,000 On Lok purchased a fully operational computer system with two CRT's and a letter quality printer. While that system has been expanded five times in the subsequent four years to meet On Lok's growing computer needs, the basic system would adequately serve most small human service providers. Today a similar system, with multi-tasking capabilities and reliable permanent storage, should cost less than \$15,000, or approximately salary-plus-fringe for one year of clerical support.

An often overlooked but vital system cost component is applications software. When On Lok developed its system, applications software for payroll and accounts payable were available and served as a base for the fiscal management system, but in areas such as client management, service recording, and scheduling, no one had even thought of computer applications. On Lok had to develop those software systems itself, and developing a coherent software application package from scratch is expensive. Over the past four years, On Lok has invested more than \$200,000 in its computerized information system. That includes all staff involvement (research,

administration, service provider, and programmer time) and rights to some software bases. Of course, some of these costs would have been required for a manual information system.

While software development costs are relatively high, once developed, software application systems can be used in other settings. For example, On Lok's IMS with relatively minor modifications could be transformed into an information system for day health, home health or other long-term care providers, for a fraction of the initial developmental cost.

There are also operating expenses. Hardware maintenance is a recommended option for any small user. Packages providing total systems support and replacement units during repair are available, usually at one percent monthly of hardware purchase price or less. Costs of supplies such as printer ribbons and paper should also be taken into consideration.

Requisite staff support is also minimal. Once an applications system is established, it does not require a full-time computer professional for its operation. A regular staff member, perhaps in accounting or administration or service program, who has an interest and some aptitude for equipment, can assume day-to-day operations responsibility. Amortizing hardware costs over a five-year period with 1982 interest rates and adding in operating costs for maintenance, supplies and some staff time for operating support, a computer system like that purchased by On Lok would cost an organization about the equivalent of the salary of a clerical staff person.

**2. Other Organizational Costs.** Computerization, like any technological change, scares people; this reaction, if anything, is more prevalent in the human service field. At On Lok, for example, many users had difficulty adjusting to the computer, felt threatened by the new tool and were afraid to use it. These feelings were anticipated and great care was taken to introduce staff to the system and to demonstrate that this technology could be their servant rather than their master. At On Lok today, over 30 staff are familiar with the use of the system and many others are asking that the system be extended to include their information needs.

**Benefits.** In addition to the many expected benefits in efficiency and quality of information, computerization has proved to be a useful resource to On Lok in many other areas. Information now plays a bigger role in improving the quality of care provided as well as the overall effectiveness of the program.

**1. Efficiency.** Computerization has greatly reduced the time requirements for all routine financial accounting and external accountability tasks. For example, a manual payroll at On Lok used to require two days—summarizing time sheets, computing salaries,

preparing checks and recording for taxes and withholding. Today, with three-times the number of employees, the entire payroll function is completed in less than six hours, and the computer does more—prints checks with employee information on all deductions and vacation, holiday and compensatory time due; tracks and monitors staff hours by department; serves as a personnel administration tool; and provides detailed personnel cost information for program management and research. All tax information is regularly computed and stored, and quarterly and annual tax reports and W-2 statements are automatically computer generated moments after the last payroll of the period is run.

With the addition of outpatient medical specialty, inpatient and housing services, On Lok's service budget has quintupled from 1978 to the present. The use of computers in accounting has allowed this phenomenal growth in personnel and program services without any increase in accounting staff. In fact, today the accounting department is not only performing all of the traditional functions, but also providing information relating to budgets, fixed assets and depreciation and program cost monitoring with the same staffing as before computerization.

Similarly, in medical records, responsibilities increased dramatically with a broader range of services, multiple centers, larger census, and more demanding reporting requirements. Computerization has automated much of the routine reporting tasks, simplifying the process and enabling more sophisticated use of information with only modest increase in medical records staff.

2. Reliability—Quality of Information. Computerization has not only increased the efficiency of information management within the program, but has also provided significant benefits in the quality of that information, i.e., its reliability and its validity. The simple use of manual information systems can increase the accuracy of participant information. In On Lok's first days, there did not even exist a clear consensus among staff regarding the number of participants being served—with estimates varying from 90 to 400! Instituting a simple manual information system—differentiated referrals, active participants and closed cases—revealed an active caseload of 77 people.

But that manual system could not easily keep up with the daily changes as new participants joined, others left, many moved and changed phone numbers — the manual information base traditionally was about 90-95% accurate. Introduction of an on-line computer system with regularly updated lists improved that reliability. It did not take many mistaken phone calls to a changed phone number to convince staff that accurate information was essential. Today, the accuracy of information routinely used by staff is over 99.5%.

Validity is more a judgment issue. Traditionally, researchers gather information that they think is relevant, appropriate and valid to the issues they address. In a service program, however,

when service staff help to construct "practical" data sets for their use, a new meaning to validity—"practical validity"—is established, and by producing information staff want and making that information available to them, On Lok has developed a data set that is more valid in meeting the needs of the service provider as well as the researcher.

**3. Utility.** A particularly significant benefit of computerization has been in the new ways information has been put to use for the On Lok program, providing service support, quality assurance, management planning, and research. On Lok, in fact, deliberately calls its system an Information Management System (IMS) rather than an Management Information System (MIS), because computer information systems are more than just for management use.

The client management system generates a range of schedules needed by service staff—attendance, meals, transportation, and health care appointments. Similar "purpose specific lists" and a computer accessible client information base have become invaluable service delivery tools, coordinating the many different services and professionals involved in community-based care.

By routinely comparing service plans to services received, the computerized information management system can monitor service plan compliance. By comparing outcomes, the information management system assists in assessing the relative benefits and costs of different treatments.

Daily, weekly and monthly status reports regularly update staff on census, services and costs. Information feedback enables the program's management to identify potential problems early, establish and monitor goals, and plan future programming. The research element of On Lok's program helps to stimulate discussion between direct service and administrative staff about the usefulness of reports and the system's performance.

**4. Cost-Effectiveness.** While it is always difficult to address the cost-effectiveness of an intervention such as computerization, the task has been made easier with cost savings alone offsetting equipment and development costs in just a few years. All of the extra information services, e.g., management reports, service and quality assurance monitoring, and the use of information in planning, development and research, have all been added dividends of the venture.

Actions ultimately speak louder than words and, in the final analysis, it is organizational behavior which speaks to the cost-effectiveness of a system. It is interesting, therefore, that in the spring of 1982, the service program staff—rather than the research staff which initiated computerization—were the ones to demand new, larger investments in more computer equipment and an expanded role for the information systems.

## Recommendations

Much has been learned through the process of computerizing the On Lok community-based long-term care system. From that experience, a number of recommendations emerge for other human service providers implementing, planning or even considering computerization.

Start small Smaller is better! Too often small or medium sized organizations overextend themselves by investing one hundred thousand dollars or more in computer equipment, only to find the equipment alone provides neither a service nor a solution. In choosing hardware, it is important to choose equipment at the appropriate level, with the capability for expansion. The single user personal computers, although inexpensive, are not realistic starting points. On the other hand, big name computer manufacturers often charge a high premium for their reputation. In selecting equipment, assess present and future needs. Buy equipment to meet your immediate needs, but assure yourself that your system can grow.

It is far safer to start with modest expectations and exceed them, than to start on a grand scale with great promises which ultimately disappoint those the system was to serve.

Kill the old-time programmer! When computers were first introduced into banking, in exchange for the benefits of the machine, bankers had to relinquish some of the control over their businesses to programmers who understood little or nothing of the business. Bankers, however, got smart. They learned enough about computers to take back control of their businesses. Now people in human services must also get smart. The age of the old-time programmer is dead. No longer can programmers be isolated physically and administratively in an organization, without training or personal interest in the content area. No longer can programmers be unwilling or unable to communicate with others who know the problems and the needs; no longer can systems be accepted which approximate the request and never fully deal with the problem. While it may be too early to find computer-literate nurses, social workers and therapists, it is time to demand that any computer professional you work with be willing to LOOK at your program and its needs, to LEARN the basics of your business, and to LISTEN to what you want in an information management system to meet your real, day-to-day needs.

Bottoms-Up! Traditionally, computer systems are developed from the top, e.g., federal and state funding agencies, who force their requirements on local agencies and, in turn, the provider. As opposed to this "top-down" method, the "bottoms-up" design approach has many advantages. Computerization should begin at the service provider level. The more diverse and demanding information needs of the service provider make them the logical starting point. Moreover, involving service providers in developing the system to meet their needs ensures their commitment to the system. Providers must meet their funding agencies' reporting requirements so these information requirements will be taken into consideration. Ultimately, a "bottoms-up" approach can produce an integrated, multi-level information network which maximizes information transfer, maintains the confidentiality of service recipients, and



meets the information requirements of state and federal funding sources. The resulting information base will permit effective program monitoring, provide a base for ongoing research and serve as a practical tool for rational service planning and policy development.

Get Involved. The primary lesson from On Lok's experience is that the service provider must get involved in its information management. Today, with diminishing resources and competition from proprietary organizations, it is no longer enough to be a concerned and caring person. The human service provider must develop the skills of the sophisticated manager, one of which is the use of information. With current information technology, if the service program administrator, its planners and its service providers do not control the information they use in day-to-day operation, they will ultimately be controlled by it.

#### SUMMARY

On Lok Senior Health Services has demonstrated the feasibility and utility of the microcomputer in meeting a long-term care program's information needs. Over a four-year period, On Lok has developed a system which meets the program, policy and research information needs of its: (1) program administrators, (2) direct service staff, (3) research and evaluation staff, and (4) program monitors from outside reimbursement/funding agencies. On Lok's introduction to computer technology came through the use of a mainframe computer, which is still used to supplement in-house capacity. The advent of microcomputing technology made it possible for On Lok to obtain its own hardware, create a dedicated system and transform the role of information in the program.

Hardware and software growth has been incremental at On Lok. Hardware is upgraded or added as On Lok's needs change and/or technological breakthroughs occur. Software development has created a Fiscal Management component, a Client Management component, and an ability to integrate the two. Software is regularly written or modified to accommodate new users and emerging information needs.

Thus community-based long-term care now has access to technology long available to and used by business and industry. At On Lok, the two areas of greatest concern in long-term care -- cost containment and quality of care -- can be continuously monitored. Feedback, i.e. knowledge of results, from the computerized information management system enables On Lok's administrative and service staff to make decisions more rationally and to modulate their strategies on the basis of sound information. In short, On Lok, an operating service program, has harnessed modern computer technology to put information to use for long-term care case management as well as program management purposes.

Although much has been accomplished at On Lok, much more is yet to be done. The system at On Lok is being expanded into new areas, such as computerized charting, computerized transfer of information for state and federal funding agencies, more sophisticated systems of information feedback, and cost tracking. Of even more interest, however, is the use of computerized

systems across providers as a tool for cooperative service program development. In addition to relating similar service programs, computers can create a network among different types of service providers within the same community; through such a network more continuity in the care of people requiring services can be provided. Finally, work is yet needed to establish a common data base which will link state, county and provider agencies. With ongoing research and planning from a common data base, a rational model of long-term care development can be achieved.

## FOOTNOTES

<sup>1</sup> The authors would like to acknowledge the contributions of many others to this paper and the development of On Lok's computerized information management system. This system would not have been possible without the commitment and support of the Executive Director, Marie-Louise Ansak, and the direct involvement of service staff like Rose Wong, the dietitian, who insisted that the computer meet her practical, day-to-day information needs. We would also like to acknowledge the contribution of Richard Lyon, On Lok's first programmer, who was instrumental in developing many of the early systems. Finally, we would like to thank Carol Van Steenberg for her editorial assistance, without whom this report would not have been possible.

<sup>2</sup> Zawadski, R. T. & Ansak, M. L. On Lok's CCODA: The first two years. San Francisco: On Lok Senior Health Services, 1981.

## **on lok's research...**

Building on its service program base, On Lok today is involved in housing, training, technical assistance, and research. The research component is described below.

The research efforts at On Lok seek to build a body of knowledge based on real world experiences with service systems in long-term care. Unlike evaluation which seeks "yes or no" answers to specific questions, On Lok's research project seeks answers to practical questions while building a better understanding of the problem.

On Lok's research approach can be described as program-based and policy-oriented. This perspective has implications for the questions that are asked, the method of inquiry and the intended audiences for dissemination.

**PROGRAM-BASED** means that research staff look to the actual experience of providers to identify relevant issues and problems. Research staff develop ongoing systems to meet providers' information needs and communicate that information in an appropriate, timely manner. The assumption underlying the program-based model is that the issues and answers relevant to a dynamic demonstration project exist with the people implementing it.

By being **POLICY-ORIENTED**, it is meant that research looks to policymakers and planners to identify the questions they have in legislating new services and policies. On Lok's information system incorporates those questions, and information is provided, when needed, in an appropriate format.

As **RESEARCH**, the project identifies and addresses new questions in the process of answering old ones. To contribute to the body of knowledge and avail the ideas to peer review, information is disseminated to the professional community through technical reports, papers and conference presentations. Each technical report focuses on a specific issue or topic which has been explored at On Lok as it relates to broader issues in the field of long-term care.

**for more information** on On Lok, its programs, services, reports and other materials, write:



---

SENIOR HEALTH SERVICES  
BAHAY PAGASA  
CENTRO DI SALUTE PER GLI ANZAINI  
安樂居  
1441 POWELL STREET  
SAN FRANCISCO, CA 94133  
(415) 989-2578